



SINGLE USE COMFORT VISOR WITH WRITE ON PANEL

PRODUCT SPECIFICATION

PACK SIZE	100
PRODUCT COLOUR	OPTICALLY CLEAR - ANTIMIST PROPERTIES
PRODUCT TYPE	FACE SHIELD
PRODUCT SIZE	330MM X 140MM
APPLICATION	MEDICAL ASSISTANT
FIELD OF USE	PROTECTION FROM LIQUIDS
STANDARDS	BS EN 166:2002 SIMPLE DESIGN CATEGORY I

MATERIALS

VISOR FILM	OPTICALLY CLEAR GRADE PET - 0.175MM THICK
FOAM HEAD COMFORT	MEDICALLY APPROVED FOAM
ELASTIC HEAD BAND	MEDICAL GRADE ELASTIC - 19MM THICK
ELASTIC FASTENING	METAL

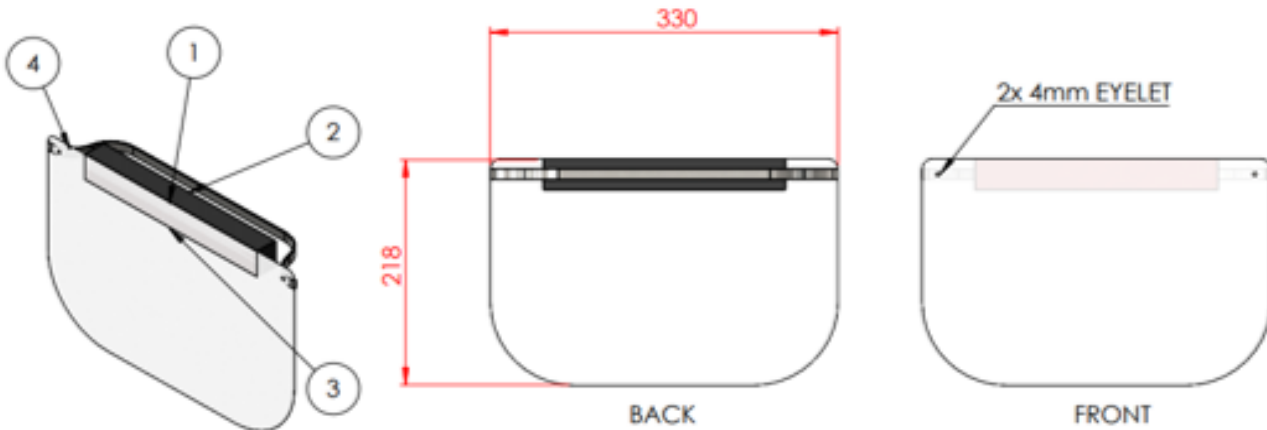

QTY'S AVAILABLE

10 PER PACK

10 PACKS PER OUTER BOX

ITEM NO.	PART NO.	DESCRIPTION	QTY
1	CM-101-01	SINGLE USE FACE VISOR FULL	1

ADDITIONAL SPECIFICATIONS

- *SINGLE USE*
- *MEDICAL GRADE MATERIALS*
- *SUITABLE TO BE USED LONG PERIODS OF TIME - DOES NOT CREATE DISTORTION*
- *ALWAYS CHECK BEFORE USE*

PRODUCT DESCRIPTION

DISPOSABLE "COMFORT" FULL FACE SHIELD TO PROVIDE ADDITIONAL PROTECTION AGAINST FLUIDS AND SPLASHES WHEN WORN WITH FACE MASKS/RESPIRATORS

CE MARKED IN ACCORDANCE WITH THE REQUIREMENTS OF BS EN 166:2002 AS SIMPLE DESIGN CATEGORY I PPE

KEY FEATURES

- *OPTICALLY CLEAR VISOR*
- *FOAM HEADBAND FOR LONG-TERM COMFORT*
- *DESIGN SUITABLE FOR PERSONS WEARING EYE PROTECTION/GLASSES/FACE MASKS*
- *LIGHTWEIGHT DESIGN*
- *PROTECTS THE FACE AND EYES FROM SPLASHING OR SPRAYING*